

REQUEST FOR PROPOSAL / PROJECT MANUAL



Kerr Technology Building 2024 Roof Project

Project Manual V1



THE GARLAND COMPANY

HIGH PERFORMANCE ROOFING AND BUILDING ENVELOPE SOLUTIONS

3800 E. 91st Street · Cleveland, Ohio 44105-2197
Phone: (216) 641-7500 · Fax: (216) 641-0633
Nationwide: 1-800-321-9336
www.garlandco.com

April 4th, 2024

Project: Cowley College Kerr Technology
Regarding: Manufacturer Assembly Letter v1
By: Rob Powers, The Garland Company

Field: Garland High Performance Low VOC Modified Assembly (30yrs)

- Wood Deck
- Insulation Adhesive - (by others, submit for approval)
- Wood fiber coverboard (by others, submit for approval)
- Primed Gypsum Coverboard - (by others, submit for approval)
- Interply Adhesive - WeatherKing Plus WC
- Field Base Sheet - StressBase 80
- Field Cap Sheet – StressPly FR mineral

Flashings:

- Flashing Adhesive - Weatherking Flashing Adhesive
- Flashing Base Sheet - Stressbase 80
- Flashing Cap Sheet - StressPly Plus FR Mineral
- Three-Course - Silver Flash and Garmesh

Accessories:

- Walkway Pads - StressPly Plus FR Mineral
- Difficult Penetrations - Tuff-Flash Plus LO and grip polyester firm
- Pitch Pockets - Gar-Rock & Tuff Flash LO
- Exposed Pitch-Pockets & Other - Tuff Flash Plus LO and White Knight
- Sealants – Green-Lock Structural Sealant
- Ladder – Submit for approval
- Drain Bowls - submit for approval if necessary

Metal Coping, Flashings, Gutter and Downspouts:

- Shop Fabricated - Garland Flat/Coil Stock

System Warranty – 30 Years Edge to Edge NDL

ABBREVIATED SCOPE OF WORK - Wood Deck Sections

ROOF FIELD – HORIZONTAL SURFACES

1. Prepare existing field membrane for installation of overlay
 - a. Power Broom Gravel off existing roof
 - b. Remove existing BUR to the coverboard.
2. Mechanically attach ½” wood fiber board as per wind uplift calculations
3. Apply insulation adhesive to surface as per wind uplift calculations
4. Place ½” gyp board into the wet adhesive immediately following application of Insulation adhesive.
5. Install Stressbase 80 base sheet in Weatherking cold adhesive
6. Install Stressply FR Mineral in Weatherking cold adhesive

ROOF WALL – VERTICAL SURFACES

1. Remove all vertical flashings down to substrate
2. Install Stressbase 80 base sheet in weatherking flashing adhesive & terminate
3. Install Stressply FR Mineral cap sheet in weatherking flashing adhesive & terminate
4. Install new specified self-adhering high temperature SA membrane over parapet
5. Cap parapet with 22ga shop fabricated Kynar 500® / Hylar 5000® steel coping (color black)
6. Three-course vertical seams with specified mastic & mesh
 - a. 3-Course all inside and outside curb corners

PROVISIONS & ACCESSORIES

1. Wind Uplift Calculations provided by Garland Engineering Services
2. Gutters to be removed & replaced with new shop fabricated
3. All drains to be re-flashed with 1/2 “sump where possible
4. All abandoned RTU’s, Equipment, and Penetrations to be removed and filled
5. Replace all pipe pillows & supports with new (Miro) to fit pipe diameter horizontal spacing
6. Paint all gas lines yellow
7. In lieu of caps, all penetration pockets to be coated with specified fluid applied membrane
8. Fascia and Soffit will need wood replaced where rotted – replace wood nailer portions. Install new metal per detail.

ABBREVIATED SCOPE OF WORK -Steel Deck Sections

ROOF FIELD – HORIZONTAL SURFACES

1. Prepare existing field membrane for installation of overlay
 - a. Power Broom Gravel off existing roof
 - b. Remove existing BUR to the coverboard.
2. Mechanically attach ½” wood fiber board as per wind uplift calculations
3. Apply insulation adhesive to surface as per wind uplift calculations
4. Place ½” gyp board into the wet adhesive immediately following application of Insulation adhesive.
5. Install Stressbase 80 base sheet in Weatherking cold adhesive
6. Install Stressply FR Mineral in Weatherking cold adhesive

ROOF WALL – VERTICAL SURFACES

1. Remove all vertical flashings down to substrate
2. Install Stressbase 80 base sheet in weatherking flashing adhesive & terminate
3. Install Stressply FR Mineral cap sheet in weatherking flashing adhesive & terminate
4. Install new specified self-adhering high temperature SA membrane over parapet
5. Cap parapet with 22ga shop fabricated Kynar 500® / Hylar 5000® steel coping (color black)
6. Three-course vertical seams with specified mastic & mesh
 - a. 3-Course all inside and outside curb corners

PROVISIONS & ACCESSORIES

1. Wind Uplift Calculations provided by Garland Engineering Services
2. Gutters to be removed & replaced with new shop fabricated
3. All drains to be re-flashed with 1/2 “sump where possible
 - a. NE drain on section D requires camera and auger ran and plumbing balloon
4. All abandoned RTU’s, Equipment, and Penetrations to be removed and filled
5. Replace all pipe pillows & supports with new (Miro) to fit pipe diameter horizontal spacing
6. Paint all gas lines yellow
7. In lieu of caps, all penetration pockets to be coated with specified fluid applied membrane
8. Fascia and Soffit will need wood replaced where rotted – replace wood nailer portions. Install new metal per detail.



THE INFORMATION CONTAINED HEREIN IS OF A PROPRIETARY NATURE AND IS SUBMITTED IN CONFIDENCE FOR USE BY THE CLIENTS APPROVED BY THE ORIGINATOR OF THIS DOCUMENT - ONLY. THE USE OF THESE DOCUMENTS FOR ANY OTHER PROJECTS, PURPOSE, LOCATION, PUBLICATION, REPRODUCTION OR DISTRIBUTION IN WHOLE OR PART, BY ANY INDIVIDUAL OR ORGANIZATION WITHOUT WRITTEN PERMISSION THE ORIGINATING COMPANY IS PROHIBITED. THE INFORMATION HEREIN REMAINS THE PROPERTY AND ITS USE OR DISCLOSURE TO OTHERS IS PROHIBITED FOR ANY USE NOT AUTHORIZED BY THE ORIGINATING COMPANY.



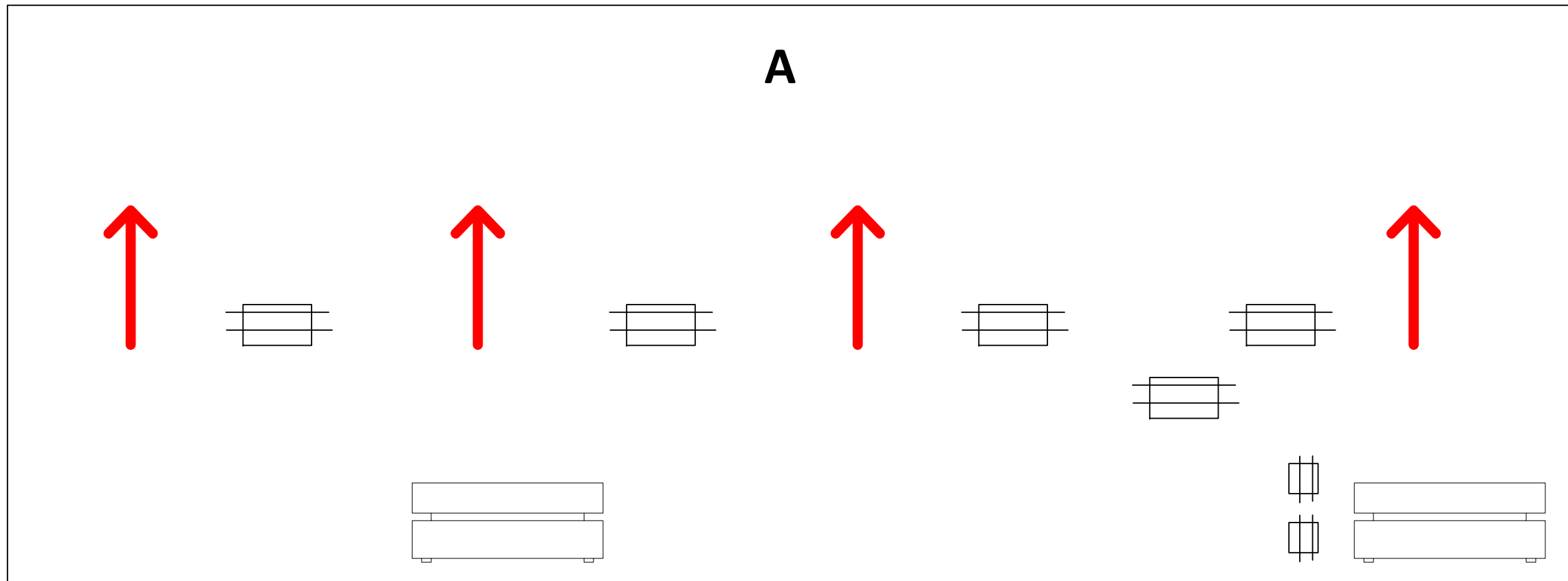

NO.	DATE	REVISION	DESCRIP.



Cowley College – Kerr Technology
 115 E 2nd St
 Arkansas City, KS 67005

Garland Representative:
 Rob Powers
 rpowers@garlandco.com
 316-648-9781

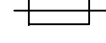

-  RTU to be Removed
-  Roof Curb
-  Scupper
-  RTU
-  Roof Drain

Deck Notes:
 Wood Deck sections A, B & C
 Steel Deck section D

** Drawing is for reference only, contractors to field verify all dimensions.**

NOTICE TO BIDDERS

Cowley College

*** Kerr Technology Building 2024 Roof Projects

Cowley College

Kerr Technology Building 2024 Roof Project

Mandatory Pre-bid Conference

Date: April 10th
Time: 12:30 PM
Place: 115 S. 2nd St Arkansas City, KS 67005

Bid-due Date Information

Date: April 19th
Time: 9:00 a.m.
Place: Bids may be delivered by hand/mailed or emailed
Email bids to holly.harper@cowley.edu

SEALED BID
Cowley College
C/O Holly Harper Kerr Technology Roof Project
125 S. 2nd Street
Arkansas City, KS 67005

Other Notables

- Specifications and Drawings
 - To be provided electronically prior to bid date (printed versions will not be made available).
- Bonds
 - 5% Bid Bond required
 - Performance and Payment upon award
- Must be Garland Certified and in good standing

*** Cowley College reserves the right to reject any and all bids and waive information and enter into such a contract as shall be deemed in the best interest of the Cowley College.

If you have any questions, please feel free to contact Rob Powers rpowers@garlandco.com or Jarrett Thummel jthummel@garlandco.com.

BID FORM

Date: _____

To: **Cowley College**

C/O Mrs. Holly Harper

Subject: Cowley College Kerr Technology Building 2024 Roof Project

Gentlemen/Ladies:

The undersigned, having been familiarized with the attached Contract Documents, which are as follows:

- Project Bid Information
- Notice to Bidders
- General Conditions
- Specifications and Scope of Work
- Drawings

All which Contract documents are made a part hereof, hereby proposes, in compliance with said Contract documents, to furnish all labors, equipment, materials, tools, supervision, etcetera, and to complete all said work as herein specified:

1. To provide Material as Specified, Supervision, Labor, and Equipment for the Roof Project **Specified Herein:**

Garland Material Quantities to be listed on OMNIA document provided

Labor & Non-Garland material \$ _____

Per Linear Foot Wood Blocking \$ _____

Per Board Foot Insulation Replacement \$ _____

Estimated Working Days to Complete _____

The undersigned understands and agrees that the Owner has the right to reject any and all bids, to waive informalities or other requirements for its benefit and to accept such proposals as it deems in its best interest.

Signature: _____

Firm: _____

Individual: _____

Title: _____

Address: _____



Omnia™ Material Form for Project: Cowley College Kerr Technology Building

It is the intent of the Owner to purchase materials for this project based upon the Agency's participation in the Omnia™ Partners, Public Sector (legacy U.S. Communities) Public Purchasing Program for Building Enclosure Supplies and Related Products and Services resulting from the competitively solicited bid as per the requirements of 42 C.F.R. § 1001.952(j); as may be amended from time to time.

As a Bidder of this Project, You are Required to Fill Out this Form and Include with Your Bid Form:

Product	Item #	Quantity
StressBase® 80	4411-80	
Description: StressBase 80 Fbgl.-reinforced SBS Mod underlayment used w/VersiPly and StressPly Cap Sheets - 80 Mil		
StressPly® FR Mineral	4365	
Description: StressPly FR Mineral Dual fiberglass reinforced SBS modified FR membrane w/min.-145 Mil		
Weatherking®	7336-55	
Cold Applied rubber modified asphalt interply adhesive		
Weatherking®	7336-5	
Cold Applied rubber modified asphalt interply adhesive		
GarMesh® 6"	4840-6	
Description: GarMesh 6" SBS coated woven fiberglass reinforcing fabric		
Weatherking® Flashing Adhesive	7306-3-M	
Description: flashing adhesive, cold applied asphalt adhesive for flashings in a weatherking system		
Green-Lock® Structural Adh.	2138-BLK	
Description: Green-Lock Structural Adh. Single component 100% solids polyether structural adhesive		
Tuff-Flash Lo	7817-3	
Tuff-Flash Plus LO (A&B) 2- part Trowel Grade Flashing and Pitch Pan Sealer		
Garland flat stock 24 gauge		
4'x10' sheets		
Garland flat stock 22 gauge		
4'x10' sheets		
Rust Go Primer	1524-SUN	
Primer for metal surfaces 5 gal pail, .25-.5 gal./sq.		
Silver Flash	7425-3	
3 gallon aluminized asphalt fibered mastic used with gar mesh		
White Knight	7828-5-U	
White-Knight Plus high strength multi-purpose urethane restoration coating		
Polyester firm	4879-12	
Grip Polyester Firm 12" [polyester reinforcement used for cold appliation over BUR or Mod		

Greenweld Flashing Boot flashing boot		
R-Mer Seal	4133	
R-Mer Seal SA, high temp, metal roof underlayment with non slip cross laminated surface		
Garla-Prime™	7612-5	
Description: Garla-Prime Quick-dry asphalt roof primer		

PLEASE NOTE:

1. It is the responsibility of the bidder to obtain any needed product-related information prior to bid submission.
2. The bidder takes full responsibility for the material quantities entered above. Any additional materials required to complete the Project over and above the quantities submitted by the bidder in this form, will be billed to the bidder directly and will not be the responsibility of the Project Owner. Any cooperatively purchased materials left over after Project completion are the property of the Project Owner.
3. Material quantities will be cross-referenced to an expected Project take-off to verify accuracy. Any bids that have material quantities substantially below or above the anticipated requirements for the Project will be rejected unless a detailed explanation is provided.
4. Material quantities will be extended using the per unit pricing for materials and added to your quote. Award evaluations will be made on the combined price of all labor and materials.



NOTICE TO BIDDERS

The NOTICE TO BIDDERS along with the following instructions constitute the formal instructions to bidders.

Pre-Bid Conference

Following the distribution of these specifications, all Contractors shall visit the job site to ensure comprehension of these specifications. Contractors who do not visit the job shall be disqualified from bidding this project.

Insurance

Contractor shall procure and maintain during life of this contract, bodily injury and property damage liability insurance under a comprehensive general form and a comprehensive automobile injury and property damage liability contract. Amounts of such bodily injury and property damage liability is stipulated herein:

a) Contractor's Comprehensive Liability Insurance

Coverage is to include a completed operation insurance for a period of one (1) year after completion of this contract.

b) Workmen's Compensation and Employer's Liability

Contractor shall maintain during life of this contract statutory workmen's compensation and employer's liability insurance for all his employees engaged in work on project.

c) Insurance Compliance

Contractor shall furnish Owner a Certificate of Insurance (COI) provided by Contractor's Insurance Agency.

d) Exchange of Policies

Contractor, by submitting the COI, acknowledges to the Owner total compliance with coverage requirements of contract documents.

e) Certificate Delivery

The Contractor shall not commence work under the contract until he has provided acceptable Certificate of Insurance and has been received by the Owner.

Guarantee

The Contractor will supply the Owner with a three (3) year warranty on labor and installation.

The Contractor must qualify as an "Approved Contractor" by the Garland Company.

Bid Opening

The Owner reserves the right to reject any or all bids and to accept the bid which, in the Owner's opinion, is in the best interest of the Owner. No bid shall be withdrawn for a period of thirty (30) days after the time set for the opening thereof.

Responsibility of Measurements and Quantities

The bidding Contractor shall be solely responsible for the accuracy of all measurements and for estimating the material quantities required to satisfy these specifications.

Pre-job Meeting

The pre-job meeting shall be held prior to the start of the project. This meeting shall include the Contractor, the Manufacturer's representative, and a representative of the Owner. The condition of the buildings and grounds areas shall be recorded and the Contractor shall be responsible for the correction and/or repair of any damage to the facilities resulting from the related work, and in addition to the conditions noted at the pre-job meeting.

Discrepancies and Addendum

Should a bidder find any discrepancies, or should Contractor be in doubt as to meaning, Contractor shall notify the assigned representative of the Owner in writing. A written addendum will be generated and sent to all qualified bidders. Oral instructions or decisions, unless confirmed by addendum, will not be considered valid or binding. All discrepancies must be submitted to the Owner's representative no later than three (3) days prior to the due date. No extras will be authorized because of the failure of the Contractor to include work called for in the addendum in their bid.

Competency of Bidder

To enable the Owner to evaluate the competency and financial responsibility of the Contractor, the winning bidder shall, if requested by Owner's Representative, furnish the following information:

- Contractor's legal name
- Contractor's business address
- Type of business entity
- Contractor's ownership and Principal Officers

- In which State was the Contractor organized
- Number of years Business
- Whether the Contractor is legally authorized to conduct business in Kansas (mandatory requirement)
- Contractor's contact person, including phone number, e-mail address, and other relevant contact information
- Letters of credit from no more than two (2) vendors or financial institutions

Contractor License Information

- Primary License Classification
- State of Kansas License Number and date issued (mandatory requirement)
- License Holder
- Type of License
- Supplemental Classification held if any
- State and explain any disciplinary actions taken by any agency of the State of Kansas to revoke or suspend the above license or attempts to investigate the license holder for business or construction related reasons

Such additional information as may be required that will satisfy the Owner that the bidder is adequately prepared in technical experience, or otherwise, to fulfill the contract.

Insurance and Bond Requirements

A Performance and Payment and 5% Bid Bond are required for this project.

Disqualification of Bidders

Any one or more of the following causes may be considered sufficient for disqualification of a bidder and the rejection of his bid or bids:

1. Failure to attend the pre-bid meeting
2. Evidence of collusion among bidders
3. Lack of responsibility as revealed by either financial, experience, or license
4. Lack of expertise as shown by past work and judged from the standpoint of workmanship and performance history
5. Uncompleted work under other contracts which, in the judgment of the Owner, might hinder or prevent the prompt completion of additional work if awarded
6. Being in arrears on existing contracts, litigation with an Owner, or having defaulted on a previous contract

Sub-Contractors

The contractor shall be prepared to submit in writing the names and places of business of any Subcontractors. The standing and ability of the Contractor and Subcontractors will be taken into consideration and agreed upon before awarding the contract.

Payment

When the job is in progress, the Owner agrees to pay upon request of the Contractor, ninety percent (90%) of the total contract price equivalent to the percentage of recognized work completed at that time.

Such payment shall be viewed by both parties as progress payments and shall not in any way relieve the Contractor of performance obligations under this contract; nor shall such payments be viewed as approval or acceptance of work performed under this contract.

Final payment shall be withheld until all provisions of the specifications are met, including all necessary clean up, and the Owner receives written verification of completion.

Waiver of Lien

Partial waiver of lien from major material suppliers and subcontractors may be required to accompany each payment request to confirm and acknowledge disbursement of the payment. Partial waivers of lien shall be properly completed and shall list the cumulative amount of payment received by the date of the waiver. If stipulated, this requirement shall not be waived unless agreed upon in writing by the Owner.

END OF NOTICE TO BIDDERS

GENERAL CONDITIONS

DESCRIPTION

The work consists of furnishing and installing all Roofing Labor and Material as specified in the accompanying documents and as specified herein.

LOCAL RULES

The Owner has certain rules, and the Contractor and Job Site Personnel shall abide by them. The Contractor shall contact the Owner's representative for specific information regarding the rules governing all operations of this project.

CONCURRENT OPERATIONS

Because other activities of the Owner will be proceeding at the same time as the work covered by this specification, the Contractor shall cooperate with the Owner's representative to ensure that all contract work progresses in a manner which does not conflict with other activities.

WORKMANSHIP

All workmen shall be thoroughly experienced in the class of work in which they are employed. All on-site materials shall be secured in place in a watertight, neat, and workmanlike manner.

CLEAN UP

Contractor shall be responsible for maintaining all work areas in a neat and orderly manner. Immediately upon completion, all cleanup shall be performed to the satisfaction of the Owner's representative.

Site must be cleaned daily with no debris or trash left on site at the end of the day.

Care must be taken to ensure that no debris falls into the roof drainage system.

Any material, tools or equipment left on site, should be secured, well kept, and protected. Said material or equipment will not fall on the liability of **the Owner** and must be covered by the contractor or sub-contractor's insurance.

Owner is not responsible for vandalism or theft of any material, tools or equipment left on site by the contractor or subcontractor.

SAFETY

The Contractor shall comply with all applicable provisions of the Occupational Safety and Health Act throughout the duration of the specified work.

INSPECTION OF WORK IN PROGRESS AND UPON COMPLETION

The Owner shall authorize the material manufacturer's representative to periodically examine the work in progress, as well as upon completion to assist in ascertaining the extent to which the

materials and procedures conform to the requirements of these specifications and to the published instruction of the material manufacturer.

The authorized material manufacturer's field representative may/shall be responsible for:

1. Providing, in writing, an agreement to provide inspection services at a minimum of three (3) times per week during progress.
2. Rendering inspection services at the Owner's representative's request and at a minimum of three (3) times per week during progress.
3. Keeping the Owner's representative informed after periodic inspections as to the progress and quality of the work as observed.
4. Calling to the attention of the Contractor those matters observed which he considers to be in violation of the contract requirements.
5. Reporting to the Owner's representative in writing any failure or refusal of the Contractor to correct unacceptable practices called to his attention.
6. Supervise the taking of test cuts and the restoration of such areas.
7. Confirming, after completion of the work based on observations and tests, the Contractor has observed no application procedures in conflict with the specifications other than those that may have been previously reported. Final payment will not be released until his confirmation has been received by the Owner.

The presence and activities of the material manufacturer's field representative shall in no way relieve the Contractor of his contractual responsibilities. In the event of a dispute, the Owner's representative shall have final authority.

Noncompliance with the terms of this specification and ensuing contract can result in either the cancellation of the contract or complete replacement of the defective areas at the Contractor's expense. In the event of cancellation, the Owner will not be obligated to compensate the Contractor for any work undertaken. Furthermore, damage caused by water infiltration resulting from the failure of the Contractor to secure each day's work in a watertight manner, will be corrected at the Contractor's expense. Included as damages will be all labor, equipment, and material costs incurred by the Owner because of such water infiltration.

TAXES (this project is tax exempt)

The Contractor shall pay all sales and use taxes, and shall pay all social security taxes, unemployment taxes and withholding taxes, and any other state, federal, and municipal requirements as directed by the governing bodies with regard to the project delivery site.

PERMITS

The Contractor shall obtain and pay for all permits, licenses, certificates, inspection, and other legal fees required, both permanent and temporary.

TEMPORARY UTILITIES

Contractor shall use at the Owner's expense, any existing electricity, lighting, water, and other utilities necessary for construction purposes.

END OF GENERAL CONDITONS

SECTION 07550
MODIFIED BITUMINOUS MEMBRANE ROOFING

PART 1 GENERAL

1.1 SECTION INCLUDES

- A. Cold Applied 2-Ply Asphalt Roofing (StressPly). (2.2.)(3.4)
- B. Accessories. (2.19)
- C. Edge Treatment and Roof Penetration Flashings. (2.20)(3.9)

1.2 RELATED SECTIONS

- A. Section 07220 - Insulation Board: Insulation and fastening.

1.3 REFERENCES

- A. ASTM D 41 - Standard Specification for Asphalt Primer Used in Roofing, Dampproofing, and Waterproofing.
- B. ASTM D 312 - Standard Specification for Asphalt used in Roofing.
- C. ASTM D 451 - Standard Test Method for Sieve Analysis of Granular Mineral Surfacing for Asphalt Roofing Products.
- D. ASTM D 1079 Standard Terminology Relating to Roofing, Waterproofing and Bituminous Materials.
- E. ASTM D 1863 Standard Specification for Mineral Aggregate Used as a Protective Coating for Roofing.
- F. ASTM D 2824 Standard Specification for Aluminum-Pigmented Asphalt Roof Coating.
- G. ASTM D 4586 Standard Specification for Asphalt Roof Cement, Asbestos-Free.
- H. ASTM D 5147 Standard Test Method for Sampling and Testing Modified Bituminous Sheet Materials.
- I. ASTM D 6162 Standard Specification for Styrene Butadiene Styrene (SBS) Modified Bituminous Sheet Materials Using a Combination of Polyester and Glass Fiber Reinforcements.
- J. ASTM D 6163 Standard Specification for Styrene Butadiene Styrene (SBS) Modified Bituminous Sheet Materials Using Glass Fiber Reinforcements.
- K. ASTM D 6164 - Standard Specification for Styrene Butadiene Styrene (SBS) Modified Bituminous Sheet Materials Using Polyester Reinforcements.
- L. ASTM E 108 - Standard Test Methods for Fire Test of Roof Coverings
- M. Factory Mutual Research (FM): Roof Assembly Classifications.
- N. National Roofing Contractors Association (NRCA): Roofing and Waterproofing Manual.

- O. Sheet Metal and Air Conditioning Contractors National Association, Inc. (SMACNA) - Architectural Sheet Metal Manual.
- P. Underwriters Laboratories, Inc. (UL): Fire Hazard Classifications.
- Q. Warnock Hersey (WH): Fire Hazard Classifications.
- R. ANSI-SPRI ES-1 Wind Design Standard for Edge Systems used with Low Slope Roofing Systems.
- S. ASCE 7, Minimum Design Loads for Buildings and Other Structures
- T. UL - Fire Resistance Directory.
- U. FM Approvals - Roof Coverings and/or RoofNav assembly database.

1.4 DESIGN / PERFORMANCE REQUIREMENTS

- A. Perform work in accordance with all federal, state and local codes.
- B. Exterior Fire Test Exposure: Roof system shall achieve a UL, FM or WH Class rating for roof slopes indicated on the Drawings as follows:
 - 1. Factory Mutual Class A Rating.
 - 2. Underwriters Laboratory Class A Rating.
 - 3. Warnock Hersey Class A Rating.
- C. Design Requirements:
 - 1. Uniform Wind Uplift Load Capacity
 - a. Installed roof system shall withstand negative (uplift) design wind loading pressures complying with the following criteria.
 - 1) Design Code: ASCE 7, Method 2 for Components and Cladding.
- D. Roof System membranes containing recycled or bio-based materials shall be third party certified through UL Environment.
- E. Roof system shall have been tested in compliance with the following codes and test requirements:
 - 1. International Code Council Evaluation Service (ICC-ES):
 - a. Membrane Systems
 - 2. Underwriters Laboratories:
 - a. Certification TGFU.
 - 3. Warnock Hersey
 - a. ITS Directory of Listed Products
 - 4. FM Approvals:
 - a. RoofNav Website

1.5 SUBMITTALS

- A. Product Data: Manufacturer's data sheets on each product to be used, including:
 - 1. Preparation instructions and recommendations.
 - 2. Storage and handling requirements and recommendations.
 - 3. Installation instructions.
- B. Shop Drawings: Submit shop drawings including installation details of roofing, flashing, fastening, insulation, including notation of roof slopes and fastening patterns of insulation and base modified bitumen membrane, prior to job start.
- C. Design Pressure Calculations: Submit design pressure calculations for the roof area in

accordance with ASCE 7 and local Building Code requirements. Garland Engineering Services to include a roof system attachment analysis report, certifying the system's compliance with applicable wind load requirements before Work begins.

- D. LEED Submittals: Provide documentation of how the requirements of Credit will be met:
 - 1. List of proposed materials with recycled content. Indicate post-consumer recycled content and pre-consumer recycled content for each product having recycled content.
 - 2. Product data and certification letter indicating percentages by weight of post-consumer and pre-consumer recycled content for products having recycled content.
 - 3. Product reflectivity and emissivity criteria to qualify for one point under the LEED credit category, Credit 7.2, Landscape & Exterior Design to Reduce Heat Island - Roof.
- E. Recycled or Bio-Based Materials: Provide third party certification through UL Environment of roof System membranes containing recycled or bio based materials.
- F. Verification Samples: For each modified bituminous membrane ply product specified, two samples, minimum size 6 inches (150 mm) square, representing actual product, color, and patterns.
- G. Manufacturer's Certificates: Provide to certify products meet or exceed specified requirements.
- H. Test Reports: Submit test reports, prepared by an independent testing agency, for all modified bituminous sheet roofing, indicating compliance with ASTM D5147.
- I. Manufacturer's Fire Compliance Certificate: Certify that the roof system furnished is approved by Factory Mutual (FM), Underwriters Laboratories (UL), Warnock Hersey (WH) or approved third party testing facility in accordance with ASTM E108, Class A for external fire and meets local or nationally recognized building codes.
- J. Closeout Submittals: Provide manufacturer's maintenance instructions that include recommendations for periodic inspection and maintenance of all completed roofing work. Provide product warranty executed by the manufacturer. Assist Owner in preparation and submittal of roof installation acceptance certification as may be necessary in connection with fire and extended coverage insurance on roofing and associated work.

1.6 QUALITY ASSURANCE

- A. Perform Work in accordance with NRCA Roofing and Waterproofing Manual.
- B. Manufacturer Qualifications: Company specializing in manufacturing products specified with documented ISO 9001 certification and minimum of twelve years of documented experience and must not have been in Chapter 11 bankruptcy during the last five years.
- C. Installer Qualifications: Company specializing in performing Work of this section with minimum five years documented experience and a certified Pre-Approved Garland Contractor.
- D. Installer's Field Supervision: Maintain a full-time Supervisor/Foreman on job site during all phases of roofing work while roofing work is in progress.
- E. Product Certification: Provide manufacturer's certification that materials are manufactured in the United States and conform to requirements specified herein, are chemically and physically compatible with each other, and are suitable for inclusion within the total roof system specified herein.
- F. Source Limitations: Obtain all components of roof system from a single manufacturer.

Secondary products that are required shall be recommended and approved in writing by the roofing system Manufacturer. Upon request of the Architect or Owner, submit Manufacturer's written approval of secondary components in list form, signed by an authorized agent of the Manufacturer.

1.7 PRE-INSTALLATION MEETINGS

- A. Convene minimum two weeks prior to commencing Work of this section.
- B. Review installation procedures and coordination required with related Work.
- C. Inspect and make notes of job conditions prior to installation:
 - 1. Record minutes of the conference and provide copies to all parties present.
 - 2. Identify all outstanding issues in writing designating the responsible party for follow-up action and the timetable for completion.
 - 3. Installation of roofing system shall not begin until all outstanding issues are resolved to the satisfaction of the Architect.

1.8 DELIVERY, STORAGE, AND HANDLING

- A. Deliver and store products in manufacturer's unopened packaging with labels intact until ready for installation.
- B. Store all roofing materials in a dry place, on pallets or raised platforms, out of direct exposure to the elements until time of application. Store materials at least 4 inches above ground level and covered with "breathable" tarpaulins.
- C. Stored in accordance with the instructions of the manufacturer prior to their application or installation. Store roll goods on end on a clean flat surface. No wet or damaged materials will be used in the application.
- D. Store at room temperature wherever possible, until immediately prior to installing the roll. During winter, store materials in a heated location with a 50 degree F (10 degree C) minimum temperature, removed only as needed for immediate use. Keep materials away from open flame or welding sparks.
- E. Avoid stockpiling of materials on roofs without first obtaining acceptance from the Architect/Engineer.
- F. Adhesive storage shall be between the range of above 50 degree F (10 degree C) and below 80 degree F (27 degree C). Area of storage shall be constructed for flammable storage.

1.9 COORDINATION

- A. Coordinate Work with installing associated metal flashings as work of this section proceeds.

1.10 PROJECT CONDITIONS

- A. Maintain environmental conditions (temperature, humidity, and ventilation) within limits recommended by manufacturer for optimum results. Do not install products under environmental conditions outside manufacturer's absolute limits.

1.11 WARRANTY

- A. Upon completion of the work, provide the Manufacturer's written and signed Edge-To-Edge NDL System Warranty, warranting that, if a leak develops in the roof during the term of this warranty, due either to defective material or defective workmanship by the installer, the

manufacturer shall provide the Owner, at the Manufacturer's expense, with the labor and material necessary to return the defective area to a watertight condition including Garland Metal Components.

1. Warranty Period:
 - a. 30 years from date of acceptance.

B. Installer is to guarantee all work against defects in materials and workmanship for a period indicated following final acceptance of the Work.

1. Warranty Period:
 - a. 3 years from date of acceptance.

PART 2 PRODUCTS

2.1 MANUFACTURERS

- A. Acceptable Manufacturer: Garland Company, Inc. (The); 3800 E. 91st St., Cleveland, OH 44105. ASD. Toll Free: 800-321-9336. Phone: 216-641-7500. Fax: 216-641-0633. WebSite: www.garlandco.com.
- B. No Substitutions. Omnia Contract Public Purchasing

2.2 COLD APPLIED 2-PLY ROOF SYSTEM - STRESSPLY

- A. Base (Ply) Sheet: One ply bonded to the prepared substrate with Interply Adhesive:
 1. StressBase 80:
- B. Modified Cap (Ply) Sheet: One ply bonded to the prepared substrate with Interply Adhesive:
 1. StressPly Plus FR Mineral:
- C. Interply Adhesive: (1 and 2)
 1. Weatherking :
- D. Flashing Base Ply: One ply bonded to the prepared substrate with Interply Adhesive:
 1. StressBase 80:
- E. Flashing Cap (Ply) Sheet: One ply bonded to the prepared substrate with Interply Adhesive:
 1. StressPly Plus FR Mineral:
- F. Flashing Ply Adhesive:
 1. Weatherking Flashing Adhesive:
- G. Surfacing: Requires 30 day wait before applying.
 1. Surface Coatings:
 - a. Garla-Brite:

2.3 ACCESSORIES:

- A. Roof Insulation: Provide Wood Fiber, G-P Gypsum DenDeck Prime, G-P Gypsum DenDeck DuraGuard, USG Securrock
 1. Wood Fiber (4'x4', ½") to be mechanically fastened through existing roof membrane and insulation assembly as per wind uplift zone calculations provided by Garland Engineering Services.
 2. Gypsum Board Primed (4'x4', ½") to be adhered to wood fiber as per wind uplift zone calculations provided by Garland Engineering Services
- B. Nails and Fasteners: Non-ferrous metal or galvanized steel, except that hard copper nails shall be used with copper; aluminum or stainless steel nails shall be used with aluminum; and stainless steel nails shall be used with stainless steel, Fasteners shall be self-clinching type of penetrating type as recommended by the deck manufacturer. Fasten nails and fasteners flush-driven through flat metal discs not less than 1 inch (25 mm) diameter. Omit

metal discs when one-piece composite nails or fasteners with heads not less than 1 inch (25 mm) diameter are used.

- C. Sealant - Green-Lock Structural Adhesive: Single component, 100% solids structural adhesive as furnished and recommended by the membrane manufacturer.
 - 1. Elongation, ASTM D 412: 300%
 - 2. Hardness, Shore A, ASTM C 920: 50
 - 3. Shear Strength, ASTM D 1002: 300 psi
- D. Non-Shrink Grout GarRock: All weather fast setting chemical action concrete material to fill pitch pans.
 - 1. Flexural Strength, ASTM C 78: (modified) 7 days 1100psi
 - 2. High Strength, ASTM C 109: (modified) 24 days 8400lbs (3810kg)
- E. Pitch Pocket Sealer – Tuff-Flash Plus LO
 - 1. Durometer, ASTM D 2240: 50 Shore
 - 2. Elongation, ASTM D 412: 325%
 - 3. Tensile Strength, ASTM D 412: 650psi
- F. Glass Fiber Cant - Glass Cant: Continuous triangular cross Section made of inorganic fibrous glass used as a cant strip as recommended and furnished by the membrane manufacturer.

2.4 EDGE TREATMENT AND ROOF PENETRATION FLASHINGS

- A. Flashing Boot - Rubbertite Flashing Boot: Neoprene pipe boot for sealing single or multiple pipe penetrations adhered in approved adhesives as recommended and furnished by the membrane manufacturer.
- B. White Knight LO
- C. Drain Flashings should be 4lb (1.8kg) sheet lead formed and rolled.
- D. Plumbing stacks should be 4lb (1.8kg) sheet lead formed and rolled.
- E. Liquid Flashing - Tuff-Flash: An asphaltic-polyurethane, low odor, liquid flashing material designed for specialized details unable to be waterproofed with typical modified membrane flashings.
 - 1. Tensile Strength, ASTM D 412: 400 psi
 - 2. Elongation, ASTM D 412: 300%
 - 3. Density @77 deg. F 8.5 lb/gal typical
 - a. PART 3 EXECUTION

3.1 EXAMINATION

- A. Do not begin installation until substrates have been properly prepared.
- B. Inspect and approve the deck condition and/or underlying and existing assembly surfaces for faults in slopes and fastener backing, parapet walls, expansion joints, roof drains, stack vents, vent outlets, nailers and surfaces and elements.
- C. Verify that work penetrating the roof deck, or which may otherwise affect the roofing, has been properly completed.
- D. If substrate preparation and other conditions are the responsibility of another installer, notify Architect of unsatisfactory preparation before proceeding.

3.2 PREPARATION

- A. General: Clean surfaces thoroughly prior to installation.
 - 1. Prepare surfaces using the methods recommended by the manufacturer for achieving

- the best result for the substrate under the project conditions.
2. Fill substrate surface voids that are greater than 1/4 inch wide with an acceptable fill material.
 3. Roof surface to receive roofing system shall be smooth, clean, free from loose gravel, dirt and debris, dry and structurally sound.
 4. Wherever necessary, all surfaces to receive roofing materials shall be power broom and vacuumed to remove debris and loose matter prior to starting work.
 5. Do not apply roofing during inclement weather. Do not apply roofing membrane to damp, frozen, dirty, or dusty surfaces.
 6. Fasteners and plates for fastening components mechanically to the substrate shall provide a minimum pull-out capacity of 300 lbs. (136 k) per fastener. Base or ply sheets attached with cap nails require a minimum pullout capacity of 40 lb. per nail.
 7. Prime decks where required, in accordance with requirements and recommendations of the primer and deck manufacturer.

3.3 INSTALLATION - GENERAL

- A. Install modified bitumen membranes and flashings in accordance with manufacturer's instructions and with the recommendations provided by the National Roofing Contractors Association's Roofing & Waterproofing Manual, the Asphalt Roofing Manufacturers Association, and applicable codes.
- B. General: Avoid installation of modified bitumen membranes at temperatures lower than 40-45 degrees F. When work at such temperatures is unavoidable use the following precautions:
 1. Take extra care during cold weather installation and when ambient temperatures are affected by wind or humidity, to ensure adequate bonding is achieved between the surfaces to be joined. Use extra care at material seam welds and where adhesion of the applied product to the appropriately prepared substrate as the substrate can be affected by such temperature constraints as well.
 2. Unrolling of cold materials, under low ambient conditions must be avoided to prevent the likelihood of unnecessary stress cracking. Rolls must be at least 40 degrees F at the time of application. If the membrane roll becomes stiff or difficult to install, it must be replaced with roll from a heated storage area.
- C. Commence installation of the roofing system at the lowest point of the roof (or roof area), working up the slope toward the highest point. Lap sheets shingle fashion so as to constantly shed water
- D. All slopes greater than 2:12 require back-nailing to prevent slippage of the ply sheets. Use ring or spiral-shank 1 inch cap nails, or screws and plates at a rate of 1 fastener per ply (including the membrane) at each insulation stop. Place insulation stops at 16 ft o.c. for slopes less than 3:12 and 4 feet o.c. for slopes greater than 3:12. On non-insulated systems, nail each ply directly into the deck at the rate specified above. When slope exceeds 2:12, install all plies parallel to the slope (strapping) to facilitate backnailing. Install 4 additional fasteners at the upper edge of the membrane when strapping the plies.

3.4 INSTALLATION COLD APPLIED ROOF SYSTEM

- A. Base Ply: Cut base ply sheets into 18 foot lengths and allow plies to relax before installing.

Install base sheet in Interply Adhesive: applied at the rate required by the manufacturer. Shingle base sheets uniformly to achieve one ply throughout over the prepared substrate. Shingle in proper direction to shed water on each large area of roofing.

1. Lap ply sheet ends 8 inches. Stagger end laps 12 inches minimum.
 2. Solidly bond to the substrate and adjacent ply with specified cold adhesive at the rate of 2 to 2-1/2 gallons per 100 square feet.
 3. Roll must push a puddle of adhesive in front of it with adhesive slightly visible at all side laps. Use care to eliminate air entrapment under the membrane.
 4. Install subsequent rolls of modified across the roof as above with a minimum of 4 inch side laps and 8 inch staggered end laps. Lay modified membrane in the same direction as the underlayers but the laps shall not coincide with the laps of the base layers.
 5. Extend plies 2 inches beyond top edges of cants at wall and projection bases.
 6. Install base flashing ply to all perimeter and projection details.
 7. Allow the one ply of base sheet to cure at least 30 minutes before installing the modified membrane. However, the modified membrane must be installed the same day as the base plies.
- B. Modified Cap Ply(s): Cut cap ply sheets into 18 foot lengths and allow plies to relax before installing. Install in interplay adhesive applied at the rate required by the manufacturer. Shingle sheets uniformly over the prepared substrate to achieve the number of plies specified. Shingle in proper direction to shed water on each large area of roofing.
1. Lap ply sheet ends 8 inches. Stagger end laps 12 inches minimum.
 2. Solidly bond to the base layers with specified cold adhesive at the rate of 2 to 2-1/2 gallons per 100 square feet.
 3. Roll must push a puddle of adhesive in front of it with adhesive slightly visible at all side laps. Care should be taken to eliminate air entrapment under the membrane.
 4. Install subsequent rolls of modified across the roof as above with a minimum of 4 inch side laps and 8 inch staggered end laps. Lay modified membrane in the same direction as the underlayers but the laps shall not coincide with the laps of the base layers.
 5. Allow cold adhesive to set for 5 to 10 minutes before installing the top layer of modified membrane.
 6. Extend membrane 2 inches beyond top edge of all cants in full moppings of the cold adhesive as shown on the Drawings.
- C. Fibrous Cant Strips: Provide non-combustible perlite or glass fiber cant strips at all wall/curb detail treatments where angle changes are greater than 45 degrees. Cant may be set in approved cold adhesives, hot asphalt or mechanically attached with approved plates and fasteners.
- D. Wood Blocking, Nailers and Cant Strips: Provide wood blocking, nailers and cant strips as specified in Section 06114.
1. Provide nailers at all roof perimeters and penetrations for fastening membrane flashings and sheet metal components.
 2. Wood nailers should match the height of any insulation, providing a smooth and even transition between flashing and insulation areas.
 3. Nailer lengths should be spaced with a minimum 1/8 inch gap for expansion and contraction between each length or change of direction.
 4. Nailers and flashings should be fastened in accordance with Factory Mutual "Loss Prevention Data Sheet 1- 49, Perimeter Flashing" and be designed to be capable of resisting a minimum force of 200 lbs/lineal foot in any direction.
- E. Metal Work: Provide metal flashings, counter flashings, parapet coping caps and thru-wall flashings as per detail and/ or shop drawings. Install in accordance with the SMACNA "Architectural Sheet Metal Manual" or the NRCA Roofing Waterproofing manual.

- F. Termination Bar: Provide a metal termination bar or approved top edge securement at the terminus of all flashing sheets at walls and curbs. Fasten the bar a minimum of 8 inches (203 mm) o/c to achieve constant compression. Provide suitable, sealant at the top edge if required.
- G. Flashing Base Ply: Install flashing sheets by the same application method used for the base ply.
1. Seal curb, wall and parapet flashings with an application of mastic and mesh on a daily basis. Do not permit conditions to exist that will allow moisture to enter behind, around or under the roof or flashing membrane.
 2. Prepare all walls, penetrations, expansion joints and where shown on the Drawings to be flashed with required primer at the rate of 100 square feet per gallon. Allow primer to dry tack free.
 3. Adhere to the underlying base ply with specified flashing ply adhesive unless otherwise specified. Nail off at a minimum of 8 inches (203 mm) o.c. from the finished roof at all vertical surfaces.
 4. Solidly adhere the entire flashing ply to the substrate. Secure the tops of all flashings that are not run up and over curb through termination bar fastened at 6 inches (152 mm) O.C. and sealed at top.
 5. Seal all vertical laps of flashing ply with a three-course application of trowel-grade mastic and fiberglass mesh.
 6. Coordinate counter flashing, cap flashings, expansion joints and similar work with modified bitumen roofing work as specified.
 7. Coordinate roof accessories, miscellaneous sheet metal accessory items, including piping vents and other devices with the roofing system work.
 8. Secure the top edge of the flashing sheet using a termination bar only when the wall surface above is waterproofed, or nailed 4 inches on center and covered with an acceptable counter flashing.
- H. Flashing Cap Ply:
1. Seal curb, wall and parapet flashings with an application of mastic and mesh on a daily basis. Do not permit conditions to exist that will allow moisture to enter behind, around or under the roof or flashing membrane.
 2. Prepare all walls, penetrations, expansion joints and where shown on the Drawings to be flashed with required primer at the rate of 100 square feet per gallon. Allow primer to dry tack free.
 3. Adhere to the underlying base flashing ply with specified flashing ply adhesive unless otherwise specified. Nail off at a minimum of 8 inches (203 mm) o.c. from the finished roof at all vertical surfaces.
 4. Coordinate counter flashing, cap flashings, expansion joints and similar work with modified bitumen roofing work as specified.
 5. Coordinate roof accessories, miscellaneous sheet metal accessory items with the roofing system work.
 6. All stripping shall be installed prior to flashing cap sheet installation.
 7. Heat and scrape granules when welding or adhering at cut areas and seams to granular surfaces at all flashings.
 8. Secure the top edge of the flashing sheet using a termination bar only when the wall surface above is waterproofed, or nailed 4 inches on center and covered with an acceptable counter flashing.
- I. Roof Walkways: Provide walkways in areas indicated on the Drawings.

3.5 INSTALLATION EDGE TREATMENT AND ROOF PENETRATION FLASHING

- A. Coping Cap:
1. Minimum flashing height is 8 inches (203 mm) above finished roof height. Maximum flashing height is 24 inches (609 mm). Prime vertical wall at a rate of 100 square feet per gallon and allow to dry.
 2. Set cant in bitumen. Run all field plies over cant a minimum of 2 inches (50 mm).
 3. Attach tapered board to top of wall.
 4. Install base flashing ply covering entire wall and wrapped over top of wall and down face with 6 inches (152 mm) on to field of roof and set in cold asphalt. Nail membrane at 8 inches (203 mm) o.c.
 5. Install a second ply of modified flashing ply in bitumen over the base flashing ply, 9 inches (228 mm) on to the field of the roof. Apply a three-course application of mastic and mesh at all seams and allow to cure and aluminize.
 6. Install continuous cleat and fasten at 6 inches (152 mm) o.c. to outside wall.
 7. Install new metal coping cap hooked to continuous cleat.
 8. Fasten inside cap 24 inches (609 mm) o.c. with approved fasteners and neoprene washers through slotted holes, which allow for expansion and contraction.
- B. Surface Mounted Counterflashing/Coping Cap:
1. Minimum flashing height is 8 inches (203 mm) above finished roof height. Prime vertical wall at a rate of 100 square feet per gallon and allow to dry.
 2. Set cant in bitumen. Run all field plies over cant a minimum of 2 inches (50 mm).
 3. Install base flashing ply covering wall set in bitumen with 6 inches (152 mm) on to field of roof.
 4. Install a second ply of modified flashing ply in bitumen over the base flashing ply, 9 inches (228 mm) on to the field of the roof. Apply a three-course application of mastic and mesh at all seams and allow to cure and aluminize.
 5. Apply butyl tape to wall behind flashing. Secure termination bar through flashing, butyl tape and into wall. Alternatively use caulk to replace the butyl tape.
 6. Secure counterflashing set on butyl tape above flashing. Fasten 8 inches (203 mm) o.c. and caulk top of counterflashing.
 7. Attach tapered board to top of wall (minimum slope 1/4 -12). Do not use organic fiberboard or perlite.
 8. Cover tapered board and all exposed wood with base flashing ply. Fasten inside and out at 8 inches (203 mm) o.c.
 9. Install continuous cleat and fasten at 6 inches (152 mm) o.c. to outside wall.
 10. Install self-adhered high temperature membrane up and over parapet.
 11. Install new metal coping cap hooked to continuous cleat.
 12. Fasten inside of cap 24 inch (609 mm) o.c. with approved fasteners and neoprene washers.
- C. Equipment Support:
1. Minimum curb height is 8 inches (203 mm) above finished roof height. Prime vertical at a rate of 100 square feet per gallon and allow to dry.
 2. Set cant in bitumen. Run all field plies over cant a minimum of 2 inches (50 mm).
 3. Install base flashing ply covering curb set in bitumen with 6 inches (152 mm) on to field of the roof.
 4. Install a second ply of modified flashing ply in bitumen over the base flashing ply, 9 inches (228 mm) on to the field of the roof. Attach top of membrane to top of curb and nail at 8 inches (203 mm) o.c. Apply a three-course application of mastic and mesh at all vertical seams and allow to cure and aluminize.
 5. Install pre-manufactured cover. Fasten sides at 24 inches (609 mm) o.c. with fasteners and neoprene washers. Furnish all joint cover laps with butyl tape between metal covers.
 6. Set equipment on neoprene pad and fasten as required by equipment manufacturer.
- D. Curb Detail/Air Handling Station:
1. Minimum curb height is 8 inches (203 mm) above finished roof height. Prime vertical at a rate of 100 square feet per gallon and allow to dry.

2. Set cant in bitumen. Run all field plies over cant a minimum of 2 inches (50 mm).
 3. Install base flashing ply covering curb set in bitumen with 6 inches (152 mm) on to field of the roof.
 4. Install a second ply of modified flashing ply in bitumen over the base flashing ply, 9 inches (228 mm) on to the field of the roof. Apply a three-course application of mastic and mesh at all vertical seams and allow to cure and aluminize.
 5. Install pre-manufactured counterflashing with fasteners and neoprene washers or per manufacturer's recommendations.
 6. Set equipment on neoprene pad and fasten as required by equipment manufacturer.
- E. Exhaust Fan:
1. Minimum curb height is 8 inches (203 mm) above finished roof height. Prime vertical at a rate of 100 square feet per gallon and allow to dry.
 2. Set cant in bitumen. Run all plies over cant a minimum of 2 inches (50 mm).
 3. Install base flashing ply covering curb with 6 inches (152 mm) on to field of the roof.
 4. Install a second ply of modified flashing ply installed over the base flashing ply, 9 inches (228 mm) on to field of the roof. Attach top of membrane to top of wood curb and nail at 8 inches (203 mm) o.c. Apply a three-course application of mastic and mesh at all vertical seams and allow to cure and aluminize.
 5. Install metal exhaust fan over the wood nailers and flashing to act as counterflashing. Fasten per manufacturer's recommendation.
- F. Roof Drain:
1. Plug drain to prevent debris from entering plumbing.
 2. Taper insulation to drain minimum of 24 inches (609 mm) from center of drain.
 3. Run roof system plies over drain. Cut out plies inside drain bowl.
 4. Set lead/copper flashing (30 inch square minimum) in 1/4 inch bed of mastic. Run lead/copper into drain a minimum of 2 inches (50 mm). Prime lead/copper at a rate of 100 square feet per gallon and allow to dry.
 5. Install base flashing ply (40 inch square minimum) in bitumen.
 6. Install modified membrane (48 inch square minimum) in bitumen.
 7. Install clamping ring and assure that all plies are under the clamping ring.
 8. Remove drain plug and install strainer.
- G. Plumbing Stack:
1. Minimum stack height is 12 inches (609 mm).
 2. Run roof system over the entire surface of the roof. Seal the base of the stack with elastomeric sealant.
 3. Prime flange of new sleeve. Install properly sized sleeves set in 1/4 inch (6 mm) bed of roof cement.
 4. Install base flashing ply in bitumen.
 5. Install membrane in bitumen.
 6. Caulk the intersection of the membrane with elastomeric sealant.
 7. Turn sleeve a minimum of 1 inch (25 mm) down inside of stack.
- H. Heat Stack:
1. Minimum stack height is 12 inches (609 mm).
 2. Run roof system over the entire surface of the roof. Seal the base of the stack with elastomeric sealant.
 3. Prime flange of new sleeve. Install properly sized sleeves set in 1/4 inch (6 mm) bed of roof cement.
 4. Install base flashing ply in bitumen.
 5. Install modified membrane in bitumen.
 6. Caulk the intersection of the membrane with elastomeric sealant.
 7. Install new collar over cape. Weld collar or install stainless steel draw brand.
- I. Pitch Pocket:
1. Run all plies up to the penetration.
 2. Place the pitch pocket over the penetration and prime all flanges.
 3. Strip in flange of pitch pocket with one ply of base flashing ply. Extend 6 inches (152

- mm) onto field of roof.
- 4. Install second layer of modified membrane extending 9 inches (228 mm) onto field of the roof.
- 5. Fill pitch pocket half full with non-shrink grout. Let this cure and top off with pourable sealant.
- 6. Caulk joint between roof system and pitch pocket with roof cement.

J. Liquid Flashing:

- 1. Mask target area on roof membrane with tape.
- 2. Clean all non-porous areas with isopropyl alcohol.
- 3. Apply 32 wet mil base coat of liquid flashing over masked area.
- 4. Embed polyester reinforcement fabric into the base coat of the liquid flashing.
- 5. Apply 48-64 wet mil top coat of the liquid flashing material over the fabric extending 2 inches (51 mm) past the scrim in all directions.
- 6. Apply minerals immediately or allow the liquid flashing material to cure 15-30 days and then install reflective coating.

3.6 CLEANING

- A. Clean-up and remove daily from the site all wrappings, empty containers, paper, loose particles and other debris resulting from these operations.
- B. Remove asphalt markings from finished surfaces.
- C. Repair or replace defaced or disfigured finishes caused by Work of this section.

3.7 PROTECTION

- A. Provide traffic ways, erect barriers, fences, guards, rails, enclosures, chutes and the like to protect personnel, roofs and structures, vehicles and utilities.
- B. Protect exposed surfaces of finished walls with tarps to prevent damage.
- C. Plywood for traffic ways required for material movement over existing roofs shall be not less than 5/8 inch (16 mm) thick.
- D. In addition to the plywood listed above, an underlayment of minimum 1/2 inch (13 mm) recover board is required on new roofing.
- E. Special permission shall be obtained from the Manufacturer before any traffic shall be permitted over new roofing.

3.8 FIELD QUALITY CONTROL

- A. Inspection: Provide manufacturer's field observations at start-up and at minimum of once ever four days. Deliver written progress/photo reports to Architect/ Owner at intervals of approximately 30 percent, 60 percent and 90 percent completion. Provide a final inspection upon completion of the Work.
 - 1. Warranty shall be issued upon manufacturer's acceptance of the installation.
 - 2. Field observations shall be performed by a Sales Representative employed full-time by the manufacturer and whose primary job description is to assist, inspect and approve membrane installations for the manufacturer.
 - 3. Provide observation reports from the Sales Representative indicating procedures followed, weather conditions and any discrepancies found during inspection.
 - 4. Provide a final report from the Sales Representative, certifying that the roofing system has been satisfactorily installed according to the project specifications, approved details and good general roofing practice.

3.9 SCHEDULES

- A. Base (Ply) Sheet:

1. StressBase 80: 80 mil SBS (Styrene-Butadiene-Styrene) rubber modified roofing base sheet reinforced with a fiberglass scrim, performance requirements according to ASTM D 5147.
 - a. Tensile Strength, ASTM D 5147
 - 1) 2 in/min. @ 0 +/- 3.6 deg. F MD 100 lbf/in XD 100 lbf/in
 - 2) 50mm/min. @ -17.78 +/- 2 deg. C MD 17.5 kN/m XD 17.5 kN/m
 - b. Tear Strength, ASTM D 5147
 - 1) 2 in/min. @ 73.4 +/- 3.6 deg. F MD 110 lbf XD 100 lbf
 - 2) 50mm/min. @ 23 +/- 2 deg. C MD 489 N XD 444 N
 - c. Elongation at Maximum Tensile, ASTM D 5147
 - 1) 2 in/min. @ 0 +/- 3.6 deg. F MD 4 % XD 4 %
 - 2) 50mm/min @ -17.78 +/- 2 deg. C MD 4 % XD 4 %
 - d. Low Temperature Flexibility, ASTM D 5147, Passes -40 deg. F (-40 deg. C)

- B. Modified Cap (Ply) Sheet:
 1. StressPly Plus FR Mineral: 155 mil SBS (Styrene-Butadiene-Styrene) mineral surfaced, rubber modified roofing membrane reinforced with a fiberglass and polyester composite scrim. ASTM D 6162, Type III Grade G
 - a. Tensile Strength, ASTM D 5147
 - 1) 2 in/min. @ 73.4 +/- 3.6 deg. F MD 310 lbf/in XD 310 lbf/in
 - 2) 50 mm/min. @ 23 +/- 2 deg. C MD 54.25 kN/m XD 54.25 kN/m
 - b. Tear Strength, ASTM D 5147
 - 1) 2 in/min. @ 73.4 +/- 3.6 deg. F MD 500 lbf XD 500 lbf
 - 2) 50 mm/min. @ 23 +/- 2 deg. C MD 2224 N XD 2224 N
 - c. Elongation at Maximum Tensile, ASTM D 5147
 - 1) 2 in/min. @ 73.4 +/- 3.6 deg. F MD 8% XD 8%
 - 2) 50 mm/min. @ 23 +/- 2 deg. C MD 8% XD 8%
 - d. Low Temperature Flexibility, ASTM D 5147, Passes -30 deg. F (-34 deg. C)

- C. Interply Adhesive:
 1. Weatherking: Rubberized, polymer modified cold process asphalt roofing bitumen V.O.C. compliant ASTM D 3019. Performance Requirements:
 - a. Non-Volatile Content ASTM D 4479 70%
 - b. Density ASTM D1475 8.9 lbs./gal.
 - c. Viscosity Stormer ASTM D562 400-500 grams
 - d. Flash Point ASTM D 93 100 deg. F min. (37 deg. C)
 - e. Slope: up to 3:12

- D. Flashing Base Ply:
 1. StressBase 80: 80 mil SBS (Styrene-Butadiene-Styrene) rubber modified roofing base sheet reinforced with a fiberglass scrim, performance requirements according to ASTM D 5147.
 - a. Tensile Strength, ASTM D 5147
 - 1) 2 in/min. @ 0 +/- 3.6 deg. F MD 100 lbf/in XD 100 lbf/in
 - 2) 50 mm/min. @ -17.78 +/- 2 deg. C MD 17.5 kN/m XD 17.5 kN/m
 - b. Tear Strength, ASTM D 5147
 - 1) 2 in/min. @ 73.4 +/- 3.6 deg. F MD 110 lbf XD 100 lbf
 - 2) 50 mm/min. @ 23 +/- 2 deg. C MD 489 N XD 444 N
 - c. Elongation at Maximum Tensile, ASTM D 5147
 - 1) 2 in/min. @ 0 +/- 3.6 deg. F MD 4 % XD 4 %
 - 2) 50 mm/min. @ -17.78 +/- 2 deg. C MD 4 % XD 4 %
 - d. Low Temperature Flexibility, ASTM D 5147
 - 1) Passes -40 deg. F (-40 deg. C)

- E. Flashing Ply Adhesive:
 1. Weatherking Flashing Adhesive: Brush grade flashing adhesive.
 - a. Non-Volatile Content ASTM D 4479 70 min.
 - b. Density ASTM D 1475 8.6 lbs./gal. (1kg/l)
 - c. Flash Point ASTM D 93 100 deg. F (37 deg. C)

F. Surfacing:

1. Flashing Cap (Ply) Sheet:

- a. StressPly Plus FR Mineral: 155 mil SBS (Styrene-Butadiene-Styrene) mineral surfaced, rubber modified roofing membrane reinforced with a fiberglass and polyester composite scrim. ASTM D 6162, Type III Grade G
- 1) Tensile Strength, ASTM D 5147
 - a) 2 in/min. @ 73.4 +/- 3.6 deg. F MD 310 lbf/in XD 310 lbf/in
 - b) 50 mm/min. @ 23 +/- 2 deg. C MD 54.25 kN/m XD 54.25 kN/m
 - 2) Tear Strength, ASTM D 5147
 - a) 2 in/min. @ 73.4 +/- 3.6 deg. F MD 500 lbf XD 500 lbf
 - b) 50 mm/min. @ 23 +/- 2 deg. C MD 2224 N XD 2224 N
 - 3) Elongation at Maximum Tensile, ASTM D 5147
 - a) 2 in/min. @ 73.4 +/- 3.6 deg. F MD 8% XD 8%
 - b) 50 mm/min. @ 23 +/- 2 deg. C MD 8% XD 8%
 - 4) Low Temperature Flexibility, ASTM D 5147, Passes -30 deg. F (-34 deg. C)

END OF SECTION

SECTION 07 22 20

LOW SLOPE ROOFING COVER BOARD

PART 1 GENERAL

1.01 SUMMARY

- A. Section Includes: Fiberglass-mat faced gypsum roof boards for application directly under roof membrane systems.

1.02 REFERENCES

- A. ASTM International (ASTM):
 1. ASTM C209 Standard Test Method for Cellulosic Fiber Insulating Board
 2. ASTM C472 Standard Test Methods for Physical Testing of Gypsum, Gypsum Plasters and Gypsum Concrete.
 3. ASTM C473 Standard Test Methods for Physical Testing of Gypsum Panel Products.
 4. ASTM C1177 Standard Specification for Glass Mat Gypsum Substrate for Use as Sheathing.
 5. ASTM D3273 Standard Test Method for Resistance to Growth of Mold on the Surface of Interior Coatings in an Environmental Chamber.
 6. ASTM E84 Standard Test Method for Surface Burning Characteristics of Building Materials
 7. ASTM E96 Standard Test Methods for Water Vapor Transmission of Materials.
 8. ASTM E108 Standard Test Methods for Fire Tests of Roof Coverings
- B. Underwriters Laboratories (UL): UL 790 Standard Test Methods for Fire Tests of Roof Coverings.

1.03 SUBMITTALS

- A. Product Data and Installation Instructions: Submit manufacturer's product data including installation instructions and substrate preparation recommendations.

1.04 QUALITY ASSURANCE

- A. Inspection: Where applicable, allow for Owner's inspection and moisture testing and reporting prior to installation of roof boards.

1.05 DELIVERY, STORAGE, AND HANDLING

- A. All components used in roofing systems, including DensDeck® Prime Roof

Boards, shall be protected from exposure to moisture before, during and after installation.

- B. Remove any plastic packaging from roof boards immediately upon receipt of delivery. Failure to remove plastic packaging may result in entrapment of condensation or moisture, which may cause application problems that are not the responsibility of manufacturer
- B. Any protective, plastic factory packaging that is used to wrap roof boards for shipment is intended to provide temporary protection from moisture exposure during transit only and is not intended to provide protection during storage after delivery.
- C. Roof boards stored outside shall be stored level and off the ground and protected by a waterproof covering. Provide means for air circulation around and under stored bundles of DensDeck® Prime Roof Boards. Use adequate supports to keep the bundles flat, level and dry.
- D. Care should also be taken during installation to avoid the accumulation of moisture in the system. Roof boards shall be covered the same day as installed. Avoid application of roof boards during rain, heavy fog and any other conditions that may deposit moisture on the surface, and avoid the overuse of non-vented, direct-fired heaters during winter months.

1.06 FIELD CONDITIONS

- A. Application standards where applicable are in accordance with design assembly specifics, system manufacturer requirements and the DensDeck® Technical Guide.
- B. Do not install DensDeck® Prime Roof Board that is moisture damaged. Indications that panels are moisture damaged include, but not limited to, discoloration, sagging, or irregular shape.
- C. Installed DensDeck® Prime Roof Boards shall be dry, with free moisture content of less than 1% using a moisture meter that has been set to the gypsum scale, before applying adhesive, asphalt or membrane.
- D. All components used in roofing systems, including DensDeck® Roof Boards, shall be protected from exposure to moisture before, during and after installation.

PART 2 PRODUCTS

2.01 MANUFACTURERS:

- A. Basis of Design: Georgia-Pacific Gypsum LLC products as specified herein.

2.02 COATED PRIME FIBERGLASS-MAT FACED GYPSUM ROOF BOARDS:

- B. Fiberglass Mat Faced Gypsum Roof Board:
1. Acceptable Product: GP Gypsum, DensDeck® Prime with EONIC™ Technology Roof Boards.
 2. Thickness: 1/2 inch.
 3. Width: 4 feet.
 4. Length: 4 feet.
 5. Weight: 2.0 lb/sq. ft.
 6. Surfacing: Primed Fiberglass Mat.
 7. Flexural Strength, Parallel (ASTM C473): 80 lbf, minimum.
 8. Flute Span (ASTM E661): 5 inches.
 9. Permeance (ASTM E96): Greater than 23 perms.
 10. R-Value (ASTM C518): 0.56.
 11. Water Absorption (ASTM C473): Less than 5 percent of weight.
 12. Surface Water Absorption (ASTM C473): Nominal 1.0 grams.
 13. Compressive Strength (Applicable Sections of ASTM C472): Nominal 900 pounds per square inch.
 14. Flame Spread/ Smoke Development (ASTM E84): Not more than 0 Flame Spread, 0 Smoke Development
 15. Combustibility (ASTM E136): Noncombustible
 16. Fire resistance rating (UL 790 and ASTM E108): Class A
 17. Mold Resistance (ASTM D3273): Scored a 10

3.02 PROTECTION

- A. Protect roof board installations from damage and deterioration until the date of Substantial Completion.

END OF SECTION 07 22 20

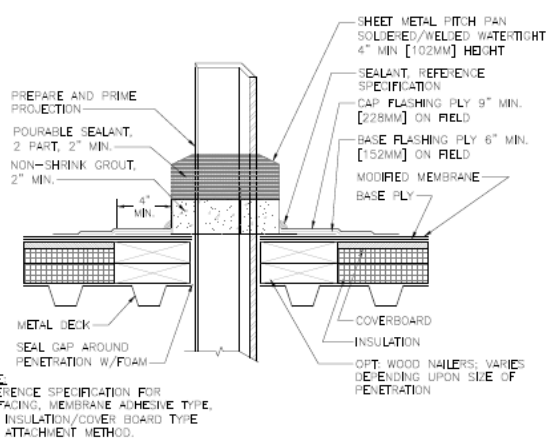

NOTE:
REFERENCE SPECIFICATION FOR SURFACING, MEMBRANE ADHESIVE TYPE, AND INSULATION/COVER BOARD TYPE AND ATTACHMENT METHOD.

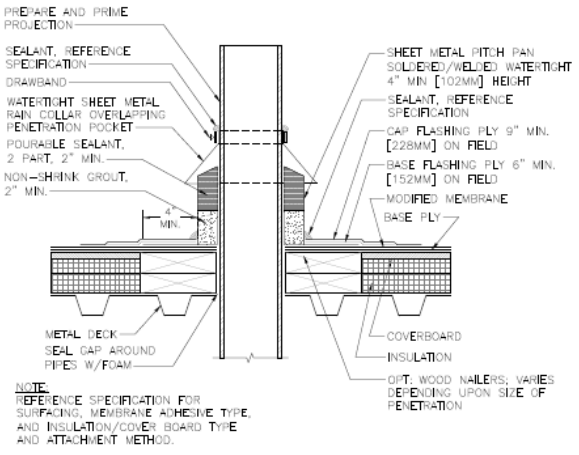

NOTE:
REFERENCE SPECIFICATION FOR SURFACING, MEMBRANE ADHESIVE TYPE, AND INSULATION/COVER BOARD TYPE AND ATTACHMENT METHOD.

DRAWINGS ON 8 1/2"x11 TITLE BLOCKS ARE NOT TO SCALE.

PITCH POCKET (STEEL ANGLE)

 <p>THE GARLAND COMPANY, INC. GARLAND CANADA, INC. THE GARLAND COMPANY UK, LTD</p>	PROJECT:	
	CUSTOMER:	
	ARCHITECT:	
	REPRESENTATIVE:	
	DATE:	SHT: OF

DRAWINGS ON 8 1/2"x11 TITLE BLOCKS ARE NOT TO SCALE.

PITCH POCKET (PIPE)

 <p>THE GARLAND COMPANY, INC. GARLAND CANADA, INC. THE GARLAND COMPANY UK, LTD</p>	PROJECT:	
	CUSTOMER:	
	ARCHITECT:	
	REPRESENTATIVE:	
	DATE:	SHT: OF

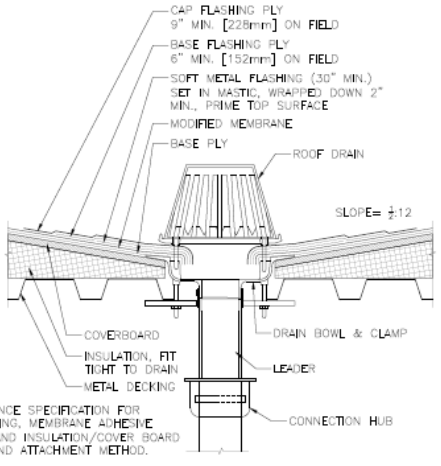

NOTE:
REFERENCE SPECIFICATION FOR SURFACING, MEMBRANE ADHESIVE TYPE, AND INSULATION/COVER BOARD TYPE AND ATTACHMENT METHOD.

DRAWINGS ON 8 1/2"x11 TITLE BLOCKS ARE NOT TO SCALE.

ROOF DRAIN

 <p>THE GARLAND COMPANY, INC. GARLAND CANADA, INC. THE GARLAND COMPANY UK, LTD</p>	PROJECT:	
	CUSTOMER:	
	ARCHITECT:	
	REPRESENTATIVE:	
	DATE:	SHT: OF

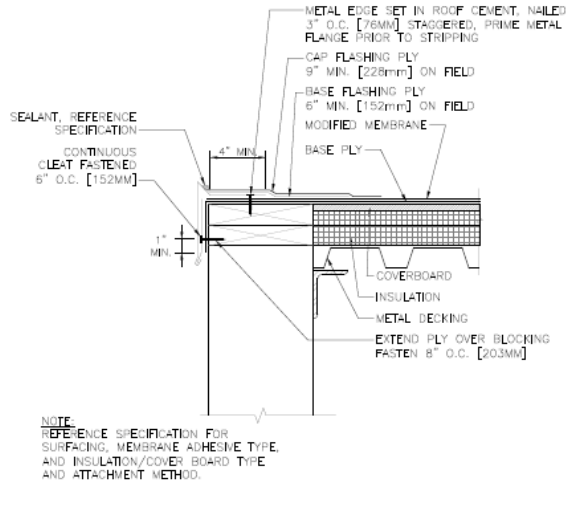

NOTE:
REFERENCE SPECIFICATION FOR SURFACING, MEMBRANE ADHESIVE TYPE, AND INSULATION/COVER BOARD TYPE AND ATTACHMENT METHOD.

DRAWINGS ON 8 1/2"x11 TITLE BLOCKS ARE NOT TO SCALE.

METAL EDGE - GRAVEL STOP

 <p>THE GARLAND COMPANY, INC. GARLAND CANADA, INC. THE GARLAND COMPANY UK, LTD</p>	PROJECT:	
	CUSTOMER:	
	ARCHITECT:	
	REPRESENTATIVE:	
	DATE:	SHT: OF

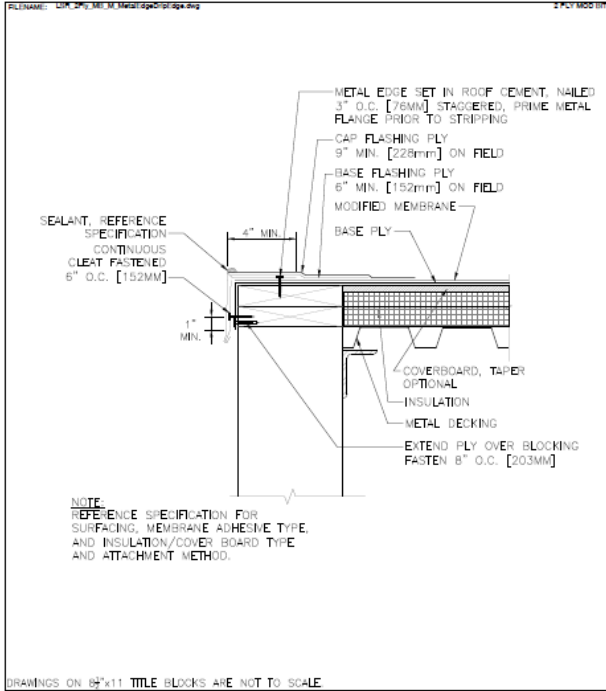

METAL EDGE - DRIP EDGE

 <p>THE GARLAND COMPANY, INC. GARLAND CANADA, INC. THE GARLAND COMPANY UK, LTD</p>	PROJECT:	
	CUSTOMER:	
	ARCHITECT:	
	REPRESENTATIVE:	
	DATE:	SHT: OF

© 2010 Garland Industries, Inc.

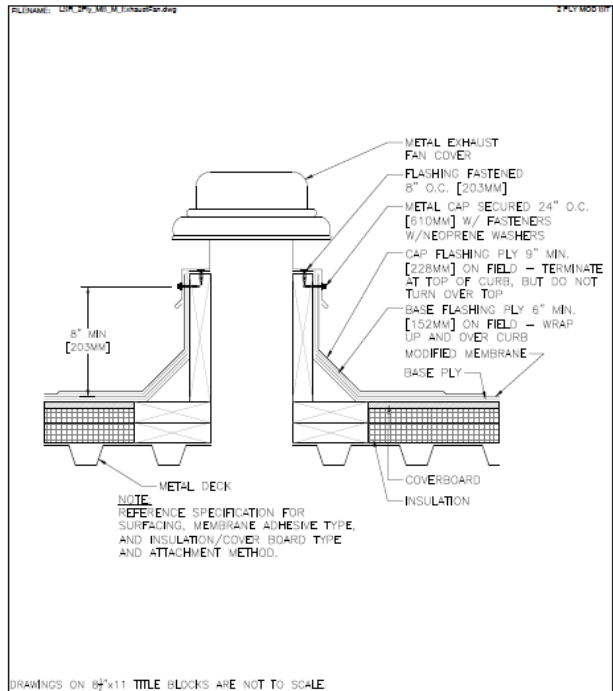

EXHAUST FAN

 <p>THE GARLAND COMPANY, INC. GARLAND CANADA, INC. THE GARLAND COMPANY UK, LTD</p>	PROJECT:	
	CUSTOMER:	
	ARCHITECT:	
	REPRESENTATIVE:	
	DATE:	SHT: OF

© 2010 Garland Industries, Inc.

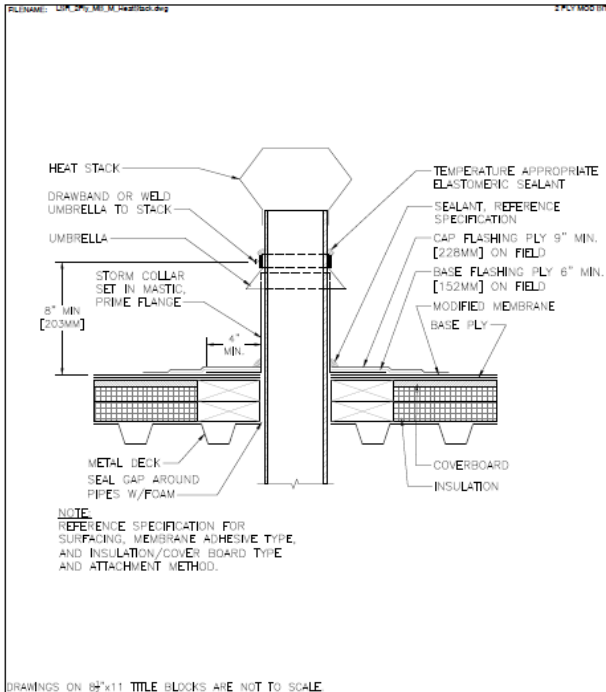

HEAT STACK

 <p>THE GARLAND COMPANY, INC. GARLAND CANADA, INC. THE GARLAND COMPANY UK, LTD</p>	PROJECT:	
	CUSTOMER:	
	ARCHITECT:	
	REPRESENTATIVE:	
	DATE:	SHT: OF

© 2010 Garland Industries, Inc.

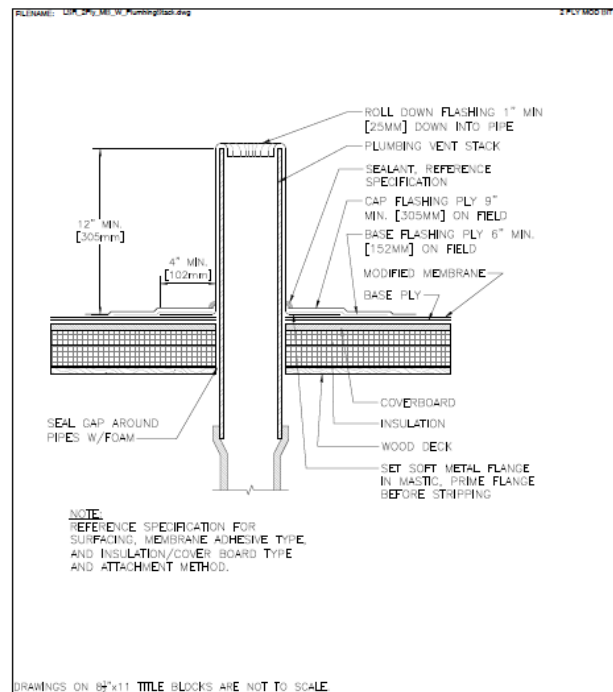

PLUMBING STACK

 <p>THE GARLAND COMPANY, INC. GARLAND CANADA, INC. THE GARLAND COMPANY UK, LTD</p>	PROJECT:	
	CUSTOMER:	
	ARCHITECT:	
	REPRESENTATIVE:	
	DATE:	SHT: OF

© 2010 Garland Industries, Inc.

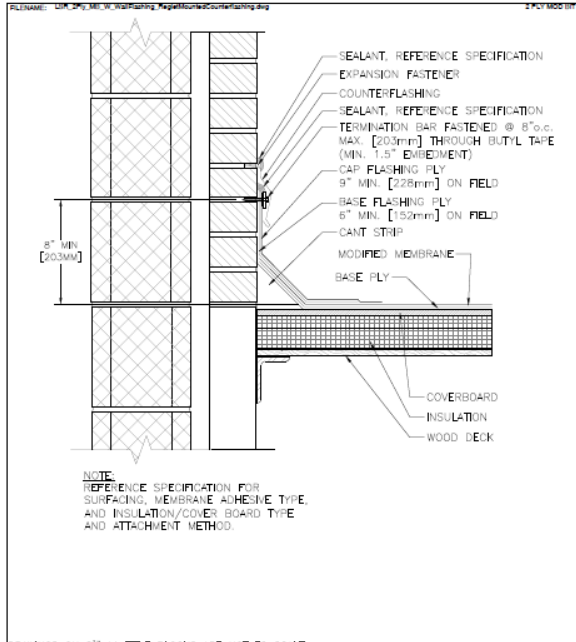

NOTE:
REFERENCE SPECIFICATION FOR SURFACING, MEMBRANE ADHESIVE TYPE AND INSULATION/COVER BOARD TYPE AND ATTACHMENT METHOD.

DRAWINGS ON 8 1/2"x11" TITLE BLOCKS ARE NOT TO SCALE

WALL FLASHING - REGLET MOUNTED COUNTERFLASHING

 <p>THE GARLAND COMPANY, INC. GARLAND CANADA, INC. THE GARLAND COMPANY UK, LTD</p>	PROJECT:	
	CUSTOMER:	
	ARCHITECT:	
	REPRESENTATIVE:	
	DATE:	SHT: OF

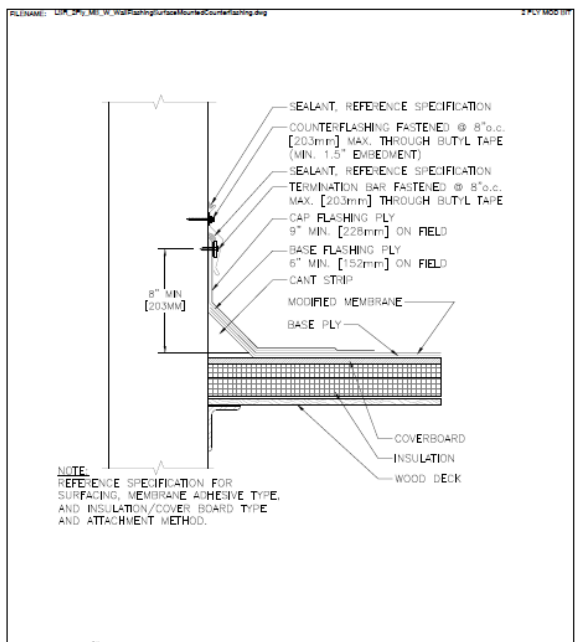



NOTE:
REFERENCE SPECIFICATION FOR SURFACING, MEMBRANE ADHESIVE TYPE AND INSULATION/COVER BOARD TYPE AND ATTACHMENT METHOD.

DRAWINGS ON 8 1/2"x11" TITLE BLOCKS ARE NOT TO SCALE

WALL FLASHING - SURFACE MOUNTED COUNTERFLASHING

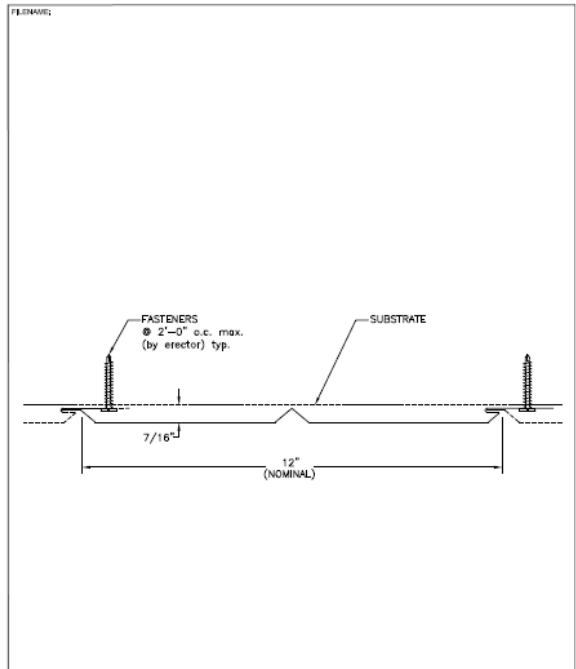
 <p>THE GARLAND COMPANY, INC. GARLAND CANADA, INC. THE GARLAND COMPANY UK, LTD</p>	PROJECT:	
	CUSTOMER:	
	ARCHITECT:	
	REPRESENTATIVE:	
	DATE:	SHT: OF



 <p>THE GARLAND COMPANY, INC. GARLAND CANADA, INC. THE GARLAND COMPANY UK, LTD</p>	LEVEL:	R-MER SOFFIT PANEL PROFILE
	SECTION:	PANEL
	DATE:	

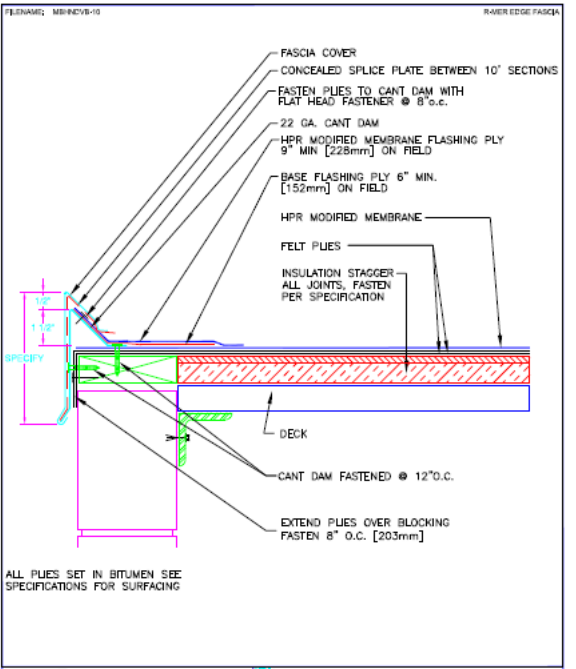

 <p>THE GARLAND COMPANY, INC. GARLAND CANADA, INC. THE GARLAND COMPANY UK, LTD</p>	LEVEL:	R-MER EDGE FASCIA
	SECTION:	GENERIC DECK
	DATE:	

AMENDMENT NUMBER 1 TO THE BID DOCUMENTS

Amendment Date: April 15, 2024

**BID DOCUMENT ADDENDUM #1
Cowley College Kerr Technology Building 2024 ROOF PROJECT**

A. This Amendment shall be considered part of the bid documents for the above-mentioned project as though it had been issued at the same time and shall be incorporated integrally therewith. Where provisions of the following supplementary data differ from those of the original bid documents, this Amendment shall govern and take precedence.

B. Bidders are hereby notified that they shall make any necessary adjustments in their estimates as a result of this Amendment. It will be construed that each bidder's proposal is submitted with full knowledge of all modifications and supplemental data specified herein.

Except as described below, the original bid document remains unchanged. The bid documents are modified and/or clarified, as follows:

Changes –

1. Bid Due date to be changed to Thursday April 25th at 1:00 PM
2. All drain strainers to be removed and replaced (submit for approval).
3. Wall flashing heights to be minimum of eight inches (8”) with saw cut reglet receiver counter flashed to cover terminations.
4. Section B, curtain wall (roof facing), remove existing compressed wood cladding down to framing substrate. Prepare new substrate to accept roof flashings, SA moisture barrier, and new shop fabricated 22ga metal panels and coping cap (exterior facing decorative panels to remain in place).
 - a. Winning contractor to submit for approval prior to fabrication/installation (panel and coping).
 - i. Example of acceptable panel profile/detail: [Flush Panel](#)
5. Add cricket at Section A, Northeast corner to accommodate proper drainage.
 - a. See Attachment B

Clarifications —

1. Electrical Contractor to remove AHUs off the roof.
2. Attachment A is abandoned and requires removal (roof Section D).
3. Owner to provide stationary ladder with brackets for contractor installation (northeast masonry wall section).

Attachments

Attachment A



Attachment B



Install cricket with 1/2" per foot slope
ensure proper drainage.

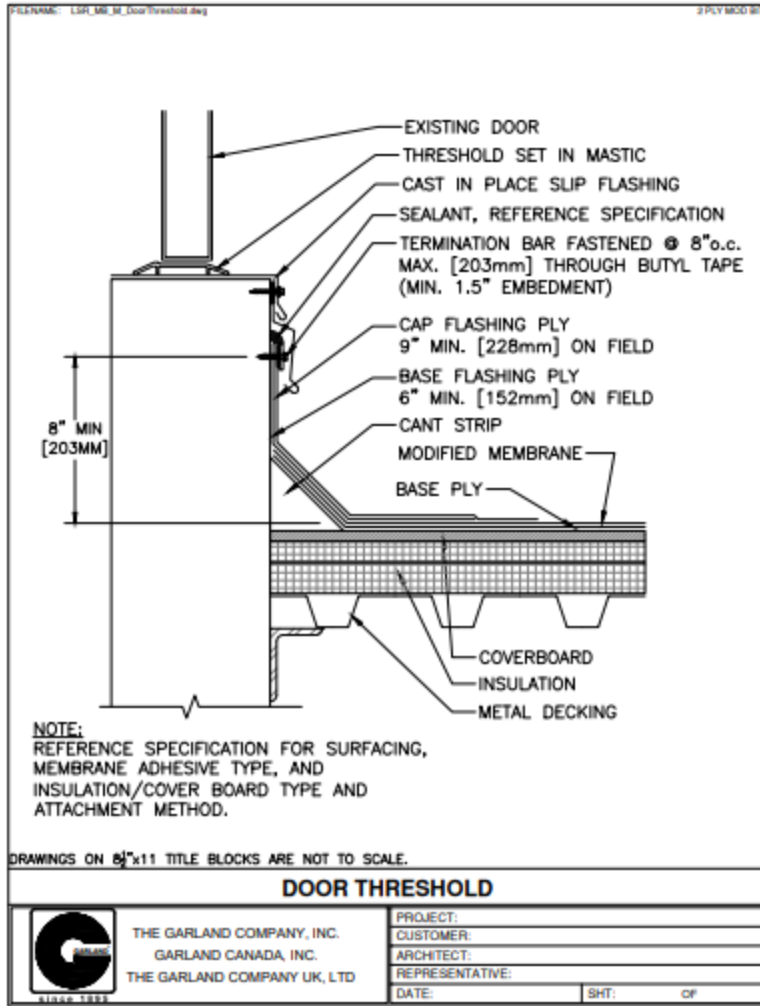

AMENDMENT NUMBER 2 TO THE BID DOCUMENTS

Amendment Date: April 22, 2024

**BID DOCUMENT ADDENDUM #2
Cowley College Kerr Technology Building 2024 ROOF PROJECT**

A. This Amendment shall be considered part of the bid documents for the above-mentioned project as though it had been issued at the same time and shall be incorporated integrally therewith. Where provisions of the following supplementary data differ from those of the original bid documents, this Amendment shall govern and take precedence.

B. Bidders are hereby notified that they shall make any necessary adjustments in their estimates as a result of this Amendment. It will be construed that each bidder's proposal is submitted with full knowledge of all modifications and supplemental data specified herein.

Except as described below, the original bid document remains unchanged. The bid documents are modified and/or clarified, as follows:

Changes –

1. Apply 2 coats of silver shield for a 36" wide walking path from the door to the ladder and around HVAC units as shown with the dotted line on Attachment A.

Clarifications —

1. Fascia and Soffit install and metal to be broken out on bid form.
2. Kruse Corp is providing a quote for roof drain scope
3. Slip flashing – wood curb supports directly on the roof
4. Wall Flashing with coping cap to have membrane run up the wall, terminated, and 3 course. Apply SA R-MER seal underlayment and then install metal coping
5. Use Greenlock Structural Adhesive on metal
6. Include Building permit fee in your quote

Attachments

Attachment A

